

FEATURES

- * **Electronic Addressing**
- * **Dual-LED for the indications of status**
- * **Optional function to check with input line**
- * **No external power supply required**
- * **Plug-in structure design for easy installation**



DESCRIPTION

VG-6711 Intelligent Monitor Interface is designed to monitor the status of connected firefighting equipment, which including water flow indicator, pressure switch, different valves, etc. When the supervised unit is activated or status changed, the interface can transmit the status or feedback to the Intelligent FD&A Panel. Moreover, there is optional function available to check with the open-circuit on input line.

DIMENSIONS

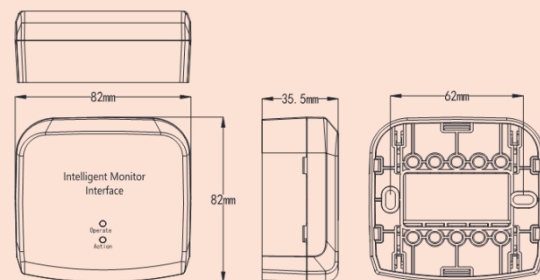

WIRING INSTRUCTION

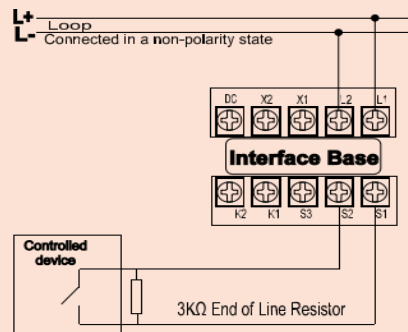

TECHNICAL DATA

Operating Voltage	DC15-28V	Temperature	-10°C ~ +50°C
Standby current	≤0.5mA	Humidity	≤95%RH (40±2°C) non-condensing
Action current	≤1.0mA	Installation	Wall-mount
Input	Passive with EOL resistor3k	Weight	About 46g
Transmit Distance	Max. 2000m	Base	VG-6613G